

# International Conference on Space Optics—ICSO 2018

Chania, Greece

9–12 October 2018

*Edited by Zoran Sodnik, Nikos Karafolas, and Bruno Cugny*



## *Optical harness (OHA) for future L-band radiometer*

*M. Piqueras*

*T. Mengual*

*J. Blasco*

*M. Aamer*

*et al.*



icso proceedings



## Optical Harness (OHA) for Future L-Band Radiometer

M. A. Piqueras\*<sup>a</sup>, T. Mengual<sup>a</sup>, J. Blasco<sup>a</sup>, M. Aamer<sup>a</sup>, O. Navasquillo<sup>a</sup>, J.I. Ramírez<sup>b</sup>

<sup>a</sup>DAS Photonics, Camino de Vera, s/n , Edificio 8F, 46022 Valencia, Spain

<sup>b</sup>Airbus Defence and Space, S.A.U., Avda. Aragón, 404, 28022 Madrid, Spain

### ABSTRACT

Soil Moisture and Ocean Salinity (SMOS) was the first ESA satellite relying on a complete optical harness, which was initially selected for the mechanical properties of optical fibre, what facilitated the deployment of the 3 arms of the instrument. In addition, other interesting advantages of the optical harness, as immunity to electromagnetic interference, high bandwidth, low losses and mass, etc., played an important role in the instrument performance.

In the frame of the the ESA ITI contract No 4000120740/17/NL/AI, based on the advantages of optical cables and the good results obtained in SMOS mission, DAS team along with Airbus DS is studying different optical harness configurations as an evolution towards a full optical harness system for a future SMOS Operational (SMOS-OPS) L-band radiometer. In particular, different Optical Harness (OHA) configurations have been studied in order to select the two most promising options.

The first configuration aims at solving some identified issues as well as at improving performance of SMOS thanks to lessons learnt from the in-orbit operation, but without attempting novel techniques of calibration or signal distribution. The second configuration explores the application of alternative techniques like the use of WDM or multi-RF over fibre. The main goals of this second configuration are the improvement of the electrical performance and the optimization of the optical harness in terms of layout, i.e, to reduce number of cables/fibres, size, weight, as well as power consumption.

**Keywords:** Interferometer, radiometer, SMOS, optical communications, optical harness

### 1. INTRODUCTION

Soil Moisture and Ocean Salinity (SMOS) belongs to a family of satellite missions that address key scientific challenges identified by the science community and demonstrate breakthrough technology in observing techniques.

The SMOS satellite was launched on November 2, 2009, and carries a novel Microwave Imaging Radiometer with Aperture Synthesis (MIRAS) that operates in the L-band microwave range to capture 'brightness temperature' images.

Interferometry requires that all receivers operate coherently, and thus, if a down-conversion is used, the local oscillator has to be distributed to all antenna elements. Also, if the signals are digitized in the antenna elements, the same sampling clock has to be distributed to all of them, and the output digital streams transferred to the cross correlator need to be synchronous to the receive clock of the correlator. Finally, a common calibration signal is needed at the input of all antenna elements to characterize instrumental errors.

SMOS was the first ESA satellite relying on a complete optical harness, which was initially selected for the mechanical properties of optical fibre, what facilitated the deployment of the three arms of the instrument. In addition, other interesting advantages of the optical harness played an important role in the instrument performance:

- Lower optical fibre transmission losses
- Better phase stability over temperature and bending in comparison with coaxial cable
- Very low electro-magnetic emission levels
- Galvanic isolation between units, as well as insensitivity to ground differential voltages
- Mass and size saving (depending on the case)

\*mapiqueras@dasphotonics.com; phone +34 963 556 150; fax +34 963 562 581; <http://www.dasphotonics.com/>

Therefore, optical signals transmission and distribution are playing an important role in the ESA future missions. Both digital and analog fiber-optic harnesses have been identified as a key enabling technology to overcome relevant limitations of traditional harness.

Based on the advantages of optical cables and the good results obtained in SMOS mission, DAS team along with Airbus DS is studying different optical harness configurations as an evolution towards a full optical harness system for a future SMOS Operational (SMOS-OPS) L-band radiometer<sup>1,2</sup>.

## 2. PRINCIPLE OF OPERATION AND ARCHITECTURE OF SMOS-OPS

SMOS objective was to provide global maps of soil moisture and ocean salinity with high accuracy, spatial and temporal resolution which is of great interest in scientific fields as agronomy, climatology, glaciological and meteorological sciences, etc.

SMOS is based on interferometry which allows to obtain an image with a brightness temperature distribution from the cross correlation of pairs of signals captured from multiple antennas looking at the target scene. Therefore the main components needed on board to perform interferometry are (a) a number of antenna elements, (b) a cross correlator and (c) a signal harness in between them.

Interferometry further requires that all receivers operate coherently, and thus, if a down conversion is used, the local oscillator (LO) has to be distributed to all antenna elements. Also, if the signals are digitized in the antenna elements, the same sampling clock has to be distributed to all of them, and the output digital streams transferred to the cross correlator need to be synchronous to the receive clock of the correlator. Finally, a common calibration signal (CAS) is needed at the input of all antenna elements to characterize instrumental errors.

The two main functions of optical harness in SMOS were the distribution of reference clock and the transmission of the IQ data signals. However, a good improvement would be to reduce the extensive use of coaxial cable required to distribute LO and CAS signals, as well as to distribute the signal from a central LO to all the receivers in order to avoid frequent LO phase calibration<sup>3,4</sup>.

The summary of the signals to be distributed in SMOS-OPS Optical Harness (OHA) are the following:

- Local Oscillator (LO) in L-band at 1384.65 MHz with the possibility to be a sinusoidal signal or a digital square with 50% duty cycle. This LO signal is transmitted from LO unit to the N antenna elements.
- Centralized calibration noise signal, an uplink of a 27 MHz L-band calibration noise centered at 1413.5 MHz. This signal is transmitted from the Calibration Unit to the N antenna elements.
- Centralized uplink of the sampling clock, a 115.3875 MHz signal (digital over-sampling clock signal). This sampling clock is transmitted from the Sampling Clock Unit to the N antenna elements. Alternatively, the sampling clock could be generated locally at the antenna elements by a 12:1 frequency division of the uplinked LO digital signal.
- Downlink output data stream from all antenna elements. The data stream consists in a multiplexed 1-bit sample stream at a rate of 230.775 Mbps.

Therefore, the preliminary SMOS-OPS Payload architecture is composed by the following parts (see Figure 1):

- The L-Band Radiometer consisting of N receivers (antenna elements) which detect the natural emission of earth in L-Band
- The Correlator which cross correlates the received signals from all pairs of Radiometer antenna elements
- The LO signal generation Unit
- The Calibration signal generation Unit
- The Sampling Clock signal generation Unit
- The Correlator, LO, Calibration and Sampling Clock Units can be physically located at the Correlator and Control Unit (CCU)

- The Optical Harness conveying in total 4 signals between the N Radiometer antenna elements and the Correlator / LO / Calibration / Sampling Clock , which will be divided in three main parts (see Figure 1):
  - Optical Transceivers in the Correlator Module: the part interfacing with the Calibration, Sampling Clock, Local Oscillator and Correlator Units; this part includes the electrical to optical conversion of the LO signal, the Calibration Signal and the Sampling Clock signal; this part includes also the O/E conversion of the data stream from the antenna elements.
  - Optical Transceivers in the Antenna Element Modules: the part interfacing with the Antenna Elements; this part includes the O/E conversion of the LO signal, the Calibration Signal and the Sampling Clock signal (if required); this part also includes the E/O conversion of the data stream output of the antenna elements as well as the derivation of the Sampling Clock signal in the antenna element from the LO signal (if required).
  - The Optical Network: the harness connecting the two modules above, implementing the uplink and downlink of the optical signals as required.

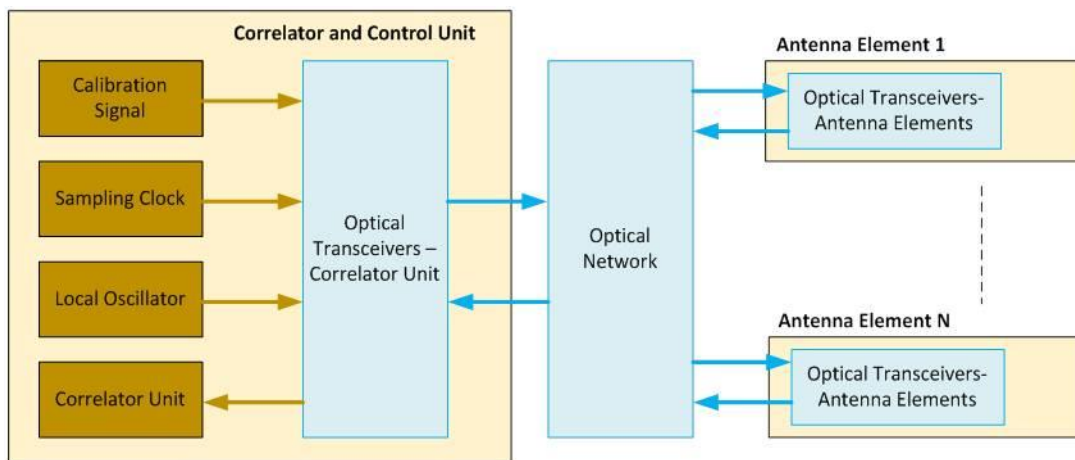


Figure 1. Scheme of the OHA

Different radiometer layout configurations have been considered during the study of the SMOS Operational mission<sup>4</sup>. As a result, two main possible configurations of the SMOS-OPS Radiometer are envisaged.

- Y-shape (i.e. 3 branches) with aprox 1 m hub and 5.4 m arms, the hub having 18 antenna elements and each arm consisting of 3 segments of 1.8 m with 12 antenna elements/segment, i.e.  $18 + 12 \times 3 \times 3 = 126$  antenna elements in total. This is a larger version of the current SMOS design (see Figure 2)
- Hexagon (i.e. 6 branches) with 6.5 m sides, each side consisting of 2 segments of 3.25 m with 22 antenna elements/segment, i.e.  $22 \times 2 \times 6 = 264$  antenna elements in total (see Figure 2)

The study of the different OHA configurations have been performed for 264 antenna elements and 12 segments, which is the one corresponding to the Hexagon-shape and worst case.

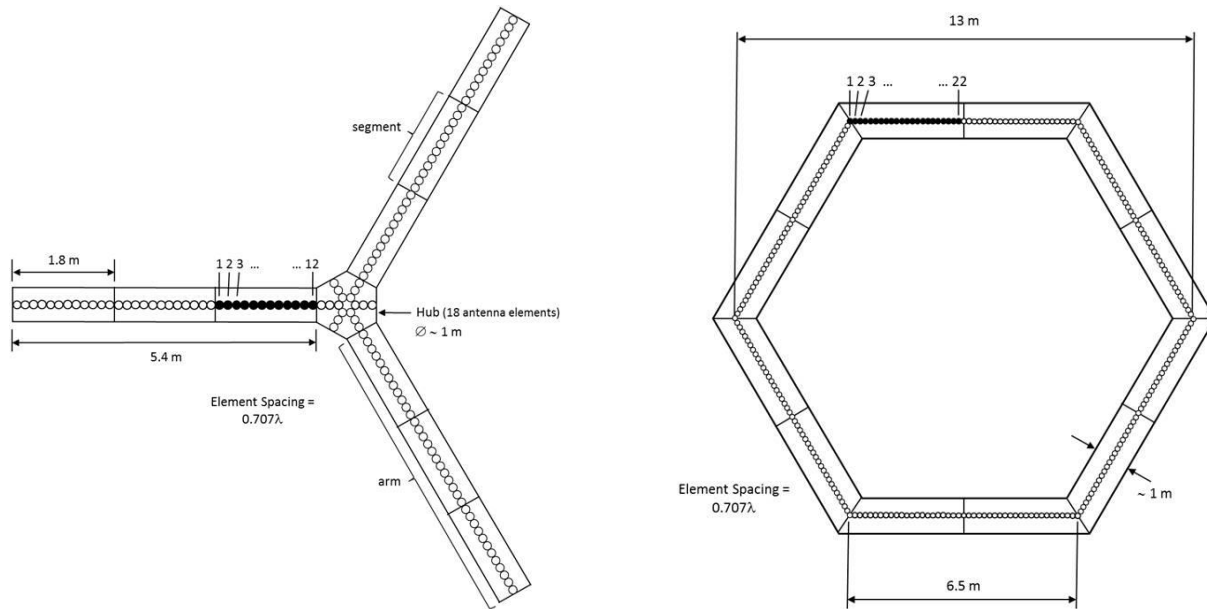


Figure 2. Y-shape and hexagonal version of an SMOS-OPS radiometer instrument

### 3. OPTICAL HARNESS DESIGN

Different Optical Harness (OHA) configurations have been studied in order to select the two most promising options for the OHA implementation. The first configuration aims at solving some identified issues as well as at improving performance of SMOS thanks to lessons learnt from the in-orbit operation, but without attempting novel techniques of calibration or signal distribution while the second one explores the application of alternative techniques like the use of WDM or multi-RF over fibre. The main goals of the second configuration are to improve electrical performance and to optimize the optical harness in terms of layout, i.e., to reduce number of cables/fibres, size, weight, as well as power consumption.

#### 3.1 OHA: configuration 1

The main elements of the optical harness are the E/O, O/E and passive parts for the optical distribution network. In the case of the optical harness for the distribution of the LO signal, based on the preliminary simulations, in order to deliver the required LO power at the antenna element (after a large level of optical splitting in the OHA), an electrical amplifier at the output of the O/E converter on the antenna element should be considered. In addition, an electrical filter would be also needed (a narrow band pass filter) to provide a positive phase noise margin to meet performance in worst case conditions of environment and ageing.

Regarding redundancy, SMOS mission has been taken as a reference where redundancy was implemented in the units that affect more than one channel. Passive optical splitters were an exception to this rule due its high reliability.

Figure 3 shows a schematic diagram of the proposed OHA for this configuration.

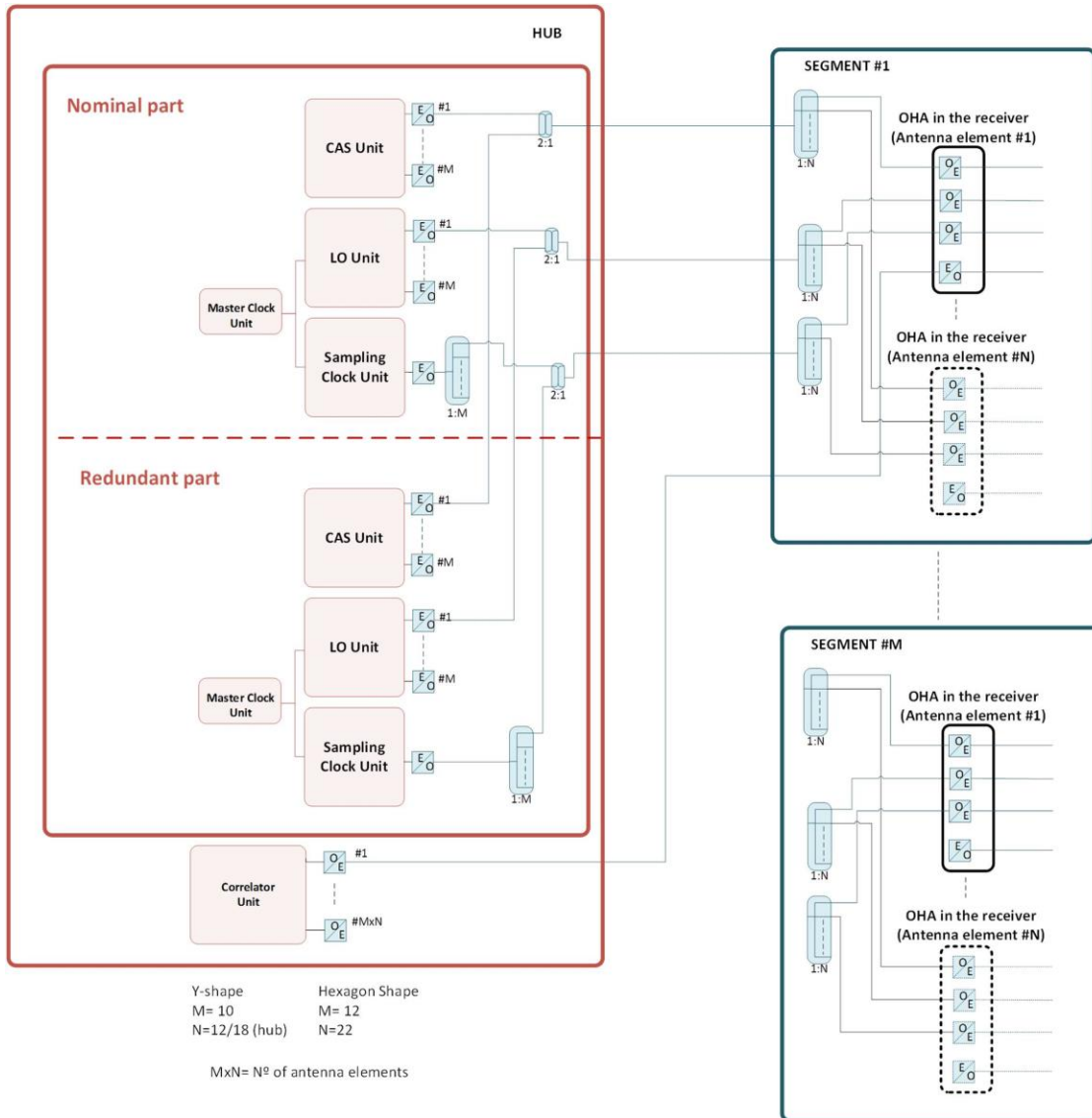


Figure 3. Configuration 1: Schematic diagram of the proposed OHA.

### 3.2 OHA: configuration 2

In configuration 2 there is considerably more flexibility for selecting the most suitable solution including: reuse of the fibre cables by multiplexing (either by RF multiplexing or by wavelength multiplexing in optics), generation of the signals either at the correlator or the antenna units, use digital or analog transmission and combine RF and optical splitting.

The configuration 2a is based on RF multiplexing of CAS, LO and CLK signals which requires to demultiplex the electrical signal at the antenna element (see Figure 4). On the other side, configuration 2b is based on wavelength division multiplexing in the optical domain (see Figure 5). In both configurations, the three signals are transmitted as analog signals over a single optical fibre.

The isolation between the CAS, CLK and LO signals is very critical, since leakages of noise from one signal to other could degrade the accuracy of the instrument. Therefore, configuration 2a requires a complex filtering stage (since the LO and CAS signals are very close). As a result, the post-photodetection RF amplification required at each antenna element increases to meet the output power requirement for the LO and CAS signals. However the use of optical demultiplexing provides isolation better than 70dB<sup>3</sup>.

Configurations 2c and 2d assume that the signals are completely digital from the generation units and only in the antenna element, the fundamental analog nature of the LO and CAS is recovered by proper filtering (see Figure 4 and 5).

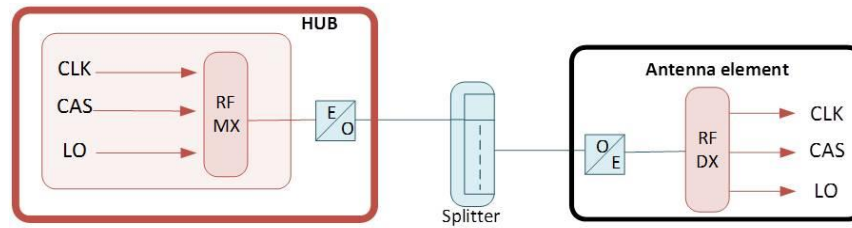


Figure 4. Configuration 2a (analog signals) and 2c (digital signals) concept

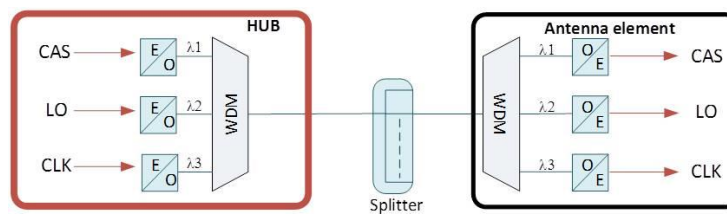


Figure 5. Configuration 2b (analog signals) and 2d (digital signals) concept

In order to alleviate the post-photodetection RF amplification, in configuration 2e it is proposed to combine the LO and CLK signals in the electrical domain and to transmit the CAS signal separately as in configuration 1 (see Figure 6). On the other side, configuration 2f, it is proposed to combine the LO and CLK signal in the electrical domain and then to use the wavelength division multiplexing in the optical domain to transmit the three signals over a single optical fibre (see Figure 7). In both configurations, 2e and 2f, the three signals are transmitted as analog signals.

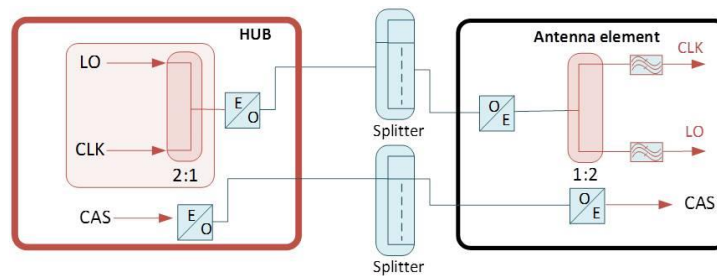


Figure 6. Configuration 2e (analog signals)

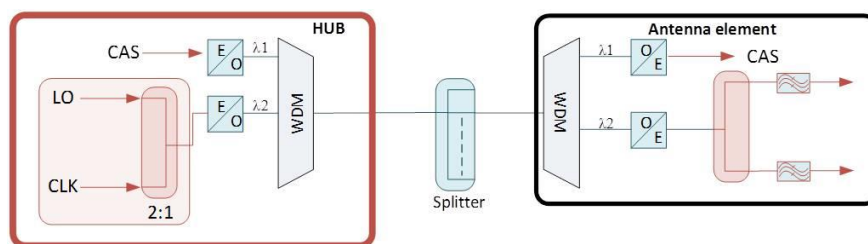


Figure 7. Configuration 2f (analog signals)

Moreover, the use of optical amplification to reduce the post-photodetection RF amplification as well as the possibility to carry out the signals splitting (at segment level) in the optical domain have been evaluated. The main goals of configuration 2 are to improve electrical performance, reduce number of cables/fibres, size, weight and power consumption. The same redundancy concept as in configuration 1 has been considered. A trade-off between 20 different configurations has been carried out. The following paragraph shows a brief description of the trade-off between most relevant configurations.

### 3.3 OHA configuration 2: Trade-off

Table 1 summarizes the key parameters for the most promising configurations, where the deviation from configuration 1 in terms of power consumption and mass is provided.

Based on these key parameters results, it can be concluded that:

- 2a configuration provides better mass figures at the antenna element, though the power consumption is much higher than for the other options.
- Although digital configuration 2c provides better mass figures, digital configurations 2c and 2d do not show any advantage over the traditional analog configurations (1a, 2b, 2e and 2f ), providing both higher power consumption and increasing the number of active elements at the antenna element side.

Therefore, configurations 2a, 2c and 2d are discarded.

Regarding the remaining configurations (2b, 2e and 2f):

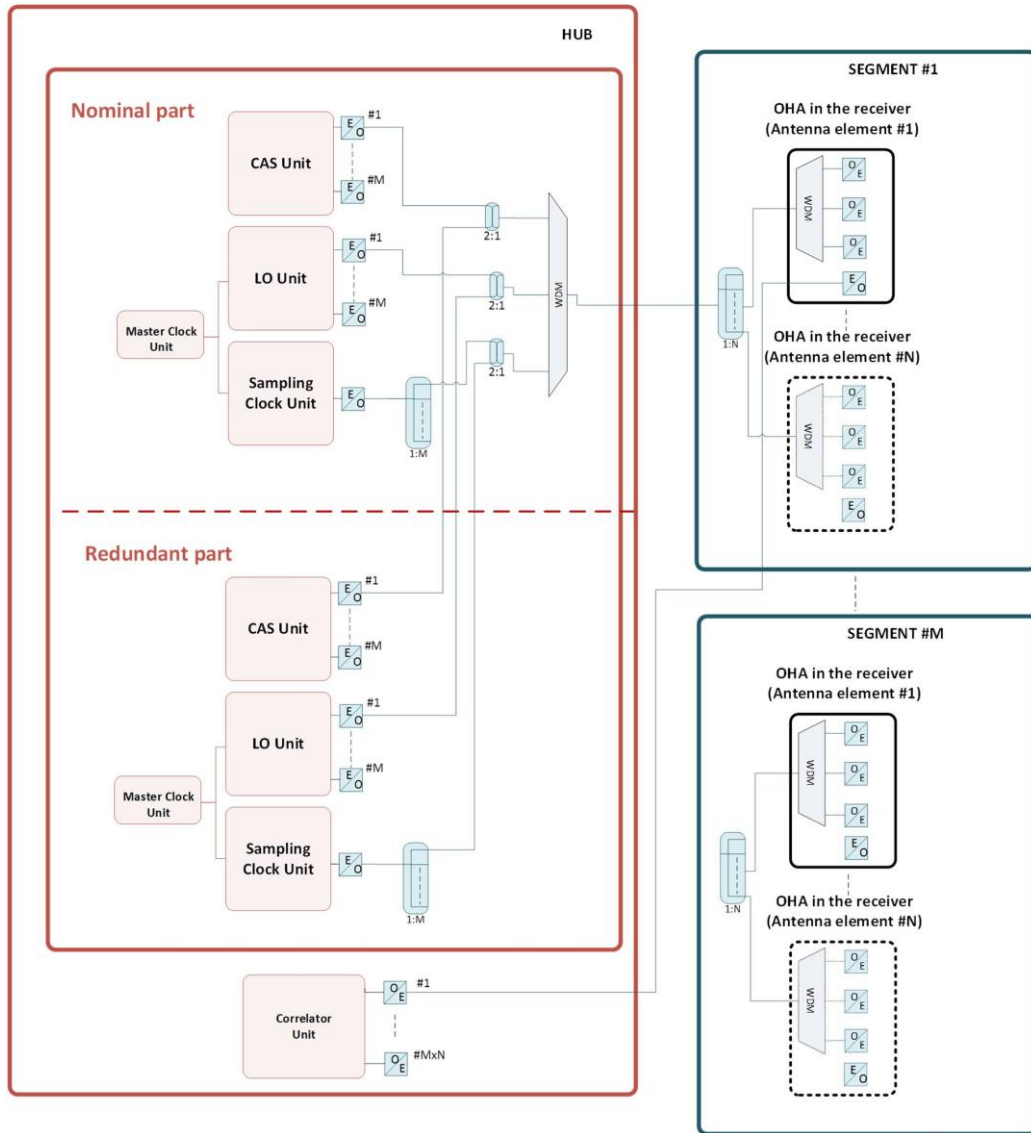
- Configuration 2b with optical amplification shows the best values in terms of power consumption and mass. Moreover, this option provides potentially better reliability figures.
- Configuration 2b without optical amplification: Although in terms of mass and power consumption is quite similar to the other remaining three configurations, it decreases the criticality in the E/O, even if qualitatively the reliability is lower than a design with less active elements (E/O). There will be one E/O for each segment, in the same way as in configuration 1. In addition, this configuration has a fully passive optical distribution network.
- Configurations 2e and 2f provide less number of actives elements side and slightly lower mass at the antenna element compared with configurations 2b. However, these approaches present higher consumption at the antenna side.

Based on the above mentioned, the final conclusion is that configurations 2b based on wavelength division multiplexing in the optical domain are the preferred option (see Figure 8).

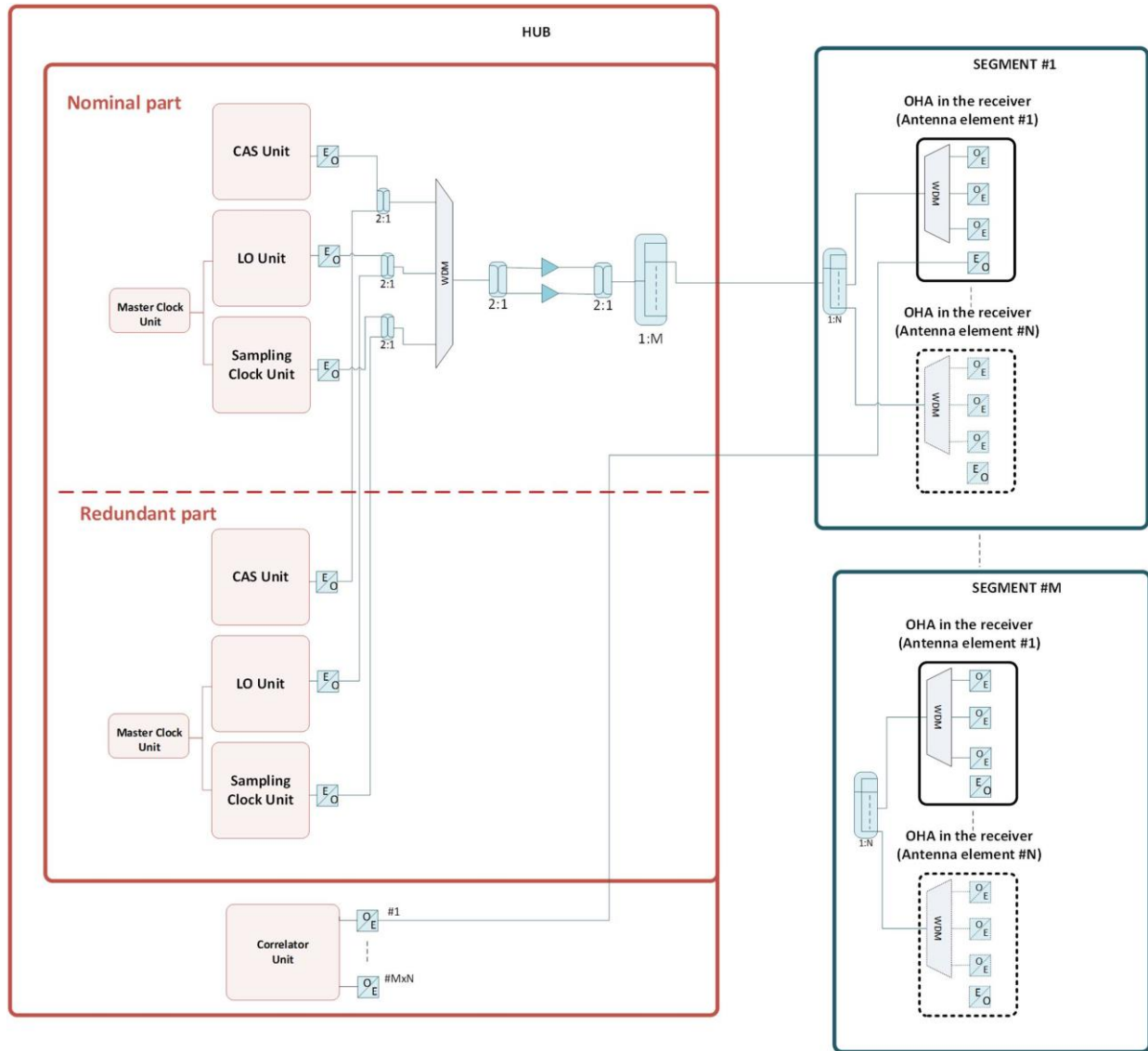


Table 1. Configuration2: key parameters for the most promising configurations.

		<b>Config. 2a</b>		<b>Config. 2b</b>		<b>Config. 2c</b>		<b>Config. 2d</b>		<b>Config. 2e</b>	<b>Config. 2f</b>
<b>Total Power Consumption</b> (Deviation from Config.1)		68%	34%	7%	-27%	24%	13%	18%	15%	5%	10%
<b>Total mass Estimation</b> (Deviation from Config.1)		-63%	-67%	-36%	-47%	-63%	-67%	-36%	-47%	-47%	-57%
<b>Hub</b>	<b>No. E/O converters</b>	24	2	50	6	24	2	50	6	4	4
	<b>No. EDFAs</b>	No	Yes	No	Yes	No	Yes	No	Yes	Yes	Yes
<b>Antenna Element</b>	<b>Power Consumption</b> (Deviation from Config.1)	149%	116%	22%	22%	104%	88%	90%	90%	67%	76%
	<b>Mass</b> (Deviation from Config.1)	-64%	-64%	-22%	-22%	-64%	-64%	-22%	-22%	-29%	-43%
	<b>Optical interfaces</b>	1	1	1	1	1	1	1	1	2	1
	<b>No. Active components</b>	5	5	6	6	7	7	11	11	5	5
	<b>No. passive components</b>	7	7	3	3	10	10	6	6	3	4



(a)



(b)

Figure 8. Configuration 2: Schematic diagram of the preferred options for the OHA implementation.

#### 4. CONCLUSIONS

Based on the advantages of optical cables and the good results obtained in SMOS mission, DAS team along with Airbus DS is studying different optical harness configurations as an evolution towards a full optical harness system for a future SMOS Operational (SMOS-OPS) L-band radiometer. In particular, different Optical Harness (OHA) configurations have been studied in order to select the two most promising options.

The first configuration studied solves some identified issues and improves performance of SMOS thanks to lessons learnt from the in-orbit operation but without attempting novel techniques of calibration or signal distribution. In particular, the main advantages of this configuration are the reduction of coaxial cable required, since the LO and CAS signals are distributed in the optical domain, and the distribution of the signal from a central LO to all the receivers in order to avoid frequent LO phase calibration.

The second configuration has explored the application of alternative techniques like analog and digital transmission of the signals, the use of WDM or multi-RF over fibre, etc... to improve electrical performance and to optimize the optical harness in terms of layout, i.e, to reduce number of cables/fibres, size, weight, as well as power consumption. In particular a trade-off over 20 configurations has been carried out to choose the most promising options. This trade-off concludes that the options based on the analog transmission of the signals over a single optical fibre by wavelength division multiplexing in the optical domain are the most promising ones.

The overall objective for the next stage of this study is to design, manufacture and test two breadboards of representative parts of configuration 1 and 2 of an advanced optical communication system for future SMOS-OPS L-band interferometric radiometer.

### ACKNOWLEDGEMENTS

This work has been supported by the European Space Agency (ESA) under the ITI contract No 4000120740/17/NL/AI ‘*Optical Harness for Future L-band Radiometer*’.

The authors thank Nikos Karafolas, Manuel Martin-Neira, François Deborgies and Willy Rits as ESA Technical officers at ESTEC, for having initiated and stimulated this activity and Ignaci Corbella from the Universitat Politècnica de Catalunya (UPC) for his scientific support.

### REFERENCES

- [1] Kudielka, K., Boehle, P., Tornell, M. et al., “Design, development and verification of the fibre-optic harness for SMOS”, *Elektrotech. Inftech.* (2007) 124/6, 175 (2007)
- [2] Kudielka, F. J. Benito-Hernández, W. Rits, M. Martin-Neira, "Fibre optics in the SMOS mission", Proc. SPIE 10565, International Conference on Space Optics (ICSO), Rhodes Island, Greece, (2010).
- [3] R. Palacio, F. Deborgies, P. Piironen, “Optical Distribution of Microwave Signals for Earth Observation Satellites”, *Microwave Photonics (MWP) IEEE 2010*.
- [4] A. Zurita, I. Corbella, M. Martín-Neira, M.A. Plaza, F. Torres, F.J. Benito, “Towards a SMOS Operational Mission: SMOSops-Hexagonal”, *IEEE Journal*, vol 6, no. 3, June 2013.